



Complete Solution for
Tube and Pipe

SB-0il Tube Master

The Brake Line Bender

ALL Electric - 3 Electric Servo Controlled Axis



SB-Oil Tube Master

The Brake Line Bender

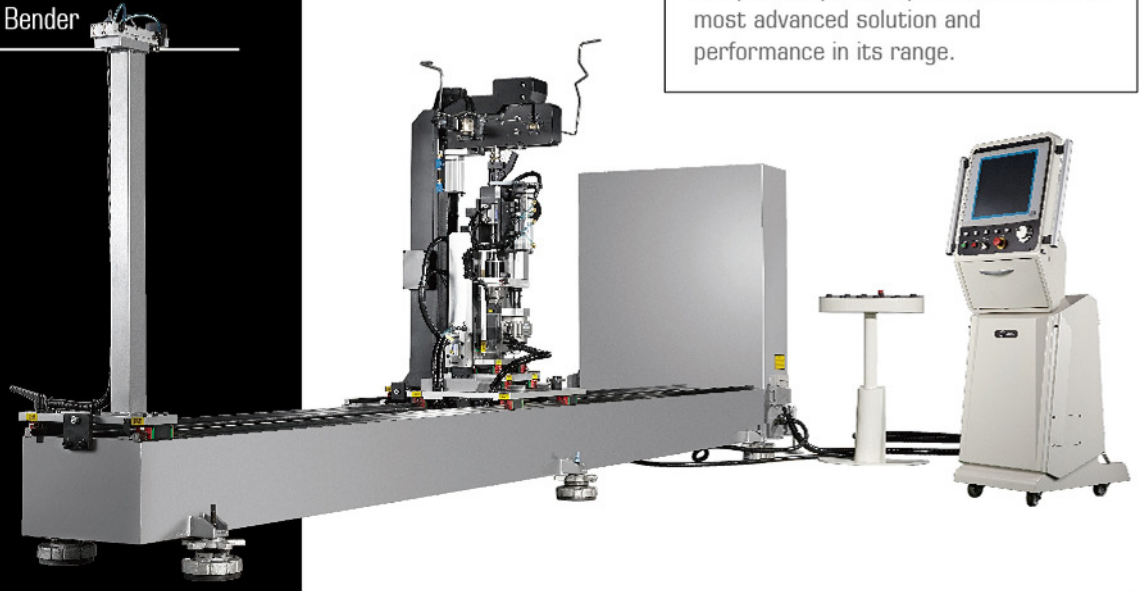

The SOCO SB-Oil Tube master is a dedicated CNC Brake Line bender, designed for small tubing, especially Bundy Tubes and hydraulic lines. With multiple electric axes and a unique design to allow bending the most complex shapes and parts, it offers the most advanced solution and performance in its range.

Automation

- 3 Electric Axis controlling bending, tube rotation and carriage movement
- Automatic bending head reversal (left-to-right) when reaching central clamping area, providing a fully automatic cycle for the entire bending process
- Optional Automatic Loading and Unloading Interface

Performance

- Centralized clamping and rotation system for true simultaneous moving of all axis
- Lowest cycle times because of minimal number of moving parts
- Suitable for brake line tubing up to 4000 mm (Optional 5000 mm)
- Unparalleled Speed:
 - 35 seconds for 14 bends
 - 100 seconds for 40 bends

Maximum Working Area = Minimal Interference

- No interference with machine bed
- No conventional bending arm
- No pressure die and wiper die seat interferences
- Central clamping and rotation away from bending zone
- Overmode (Arm Return Mode) capabilities

Software

- May program up to 49 bends per part, with on-screen 3D part display
- Data entry for both XYZ and YBC coordinates
- Overmode (Arm Return Mode) offers flexibility to offset each bend and avoid bending interferences.
- Integrated Automatic Bending Compensation and Reverse Engineering of bends when connected to CMM Measuring systems
- Connection to Local Area Network (LAN) (Optional)

Specifications / Model	SB-Oil Tube Master
Max. Mild Steel Capacity (mm)	Ø8 x 0.7t x CLR3.0D
Max. Tube Length (mm) (*)	4000
Bending Radius (mm)	15 ~ 35(CLR)
Max. Bending Angle	160°
Numbers of Bend Per Tube (*)	49
Gross Weight (Kg)	3500
Machine Dimension (mm) (LxWxH)	4900 x 1150 x 1450

(*) May be extended upon request

Due to continuous improvements and designs; the manufacturer reserves the right to modify or make any changes of all models without notice.

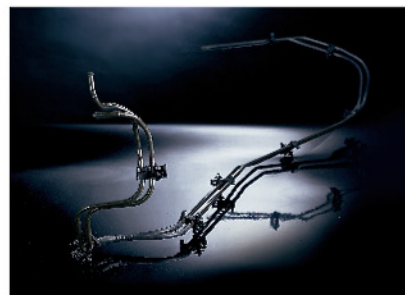

www.soco.com.tw

SOCO MACHINERY CO., LTD.

NO.3, JINGKE E. RD., NANTUN DIST.,
TAICHUNG CITY 40852, TAIWAN
T : 886-4-23591888 F : 886-4-23592386
E : sales@soco.com.tw



140731/02T